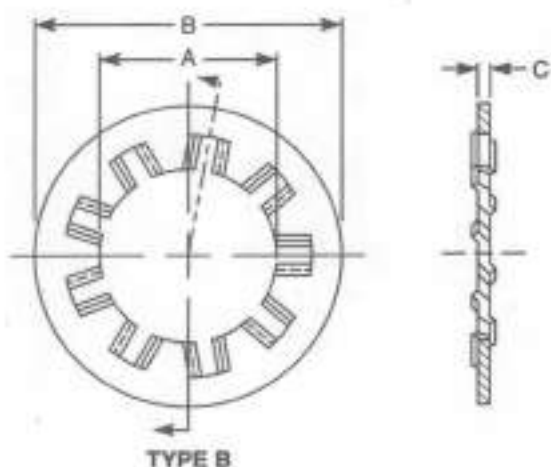
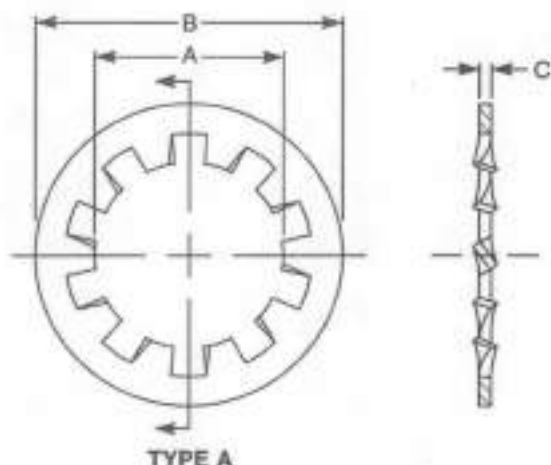

Table 6 Dimensions of Internal Tooth Lock Washers

Nominal Washer Size	A		B		C	
	Inside Diameter		Outside Diameter		Thickness	
	Max	Min	Max	Min	Max	Min
No. 2 0.086	0.095	0.089	0.200	0.175	0.016	0.010
No. 3 0.099	0.109	0.102	0.232	0.215	0.016	0.010
No. 4 0.112	0.123	0.115	0.270	0.245	0.018	0.012
No. 5 0.125	0.136	0.129	0.280	0.255	0.020	0.014
No. 6 0.138	0.150	0.141	0.295	0.275	0.022	0.016
No. 8 0.164	0.176	0.168	0.340	0.325	0.023	0.018
No. 10 0.190	0.204	0.195	0.381	0.365	0.024	0.018
No. 12 0.216	0.231	0.221	0.410	0.394	0.027	0.020
1/4 0.250	0.267	0.256	0.478	0.460	0.028	0.023
5/16 0.3125	0.332	0.320	0.610	0.594	0.034	0.028
3/8 0.375	0.398	0.384	0.692	0.670	0.040	0.032
7/16 0.4375	0.464	0.448	0.789	0.740	0.040	0.032
1/2 0.500	0.530	0.512	0.900	0.867	0.045	0.037
9/16 0.5625	0.596	0.576	0.965	0.957	0.045	0.037
5/8 0.625	0.663	0.640	1.071	1.045	0.050	0.042
11/16 0.6875	0.728	0.704	1.168	1.130	0.050	0.042
3/4 0.750	0.795	0.769	1.245	1.220	0.055	0.047
13/16 0.8125	0.861	0.832	1.315	1.290	0.055	0.047
7/8 0.875	0.927	0.894	1.410	1.364	0.060	0.052
1 1.000	1.060	1.019	1.637	1.590	0.067	0.059
1-1/8 1.125	1.192	1.144	1.830	1.799	0.067	0.059
1-1/4 1.250	1.325	1.275	1.975	1.921	0.067	0.059



NOTES:

- (1) For additional requirements, refer to Section 3, page L-14.
- (2) All dimensions are in inches.

Table 7 Dimensions of Heavy Internal Tooth Lock Washers

Nominal Washer Size	A		B		C	
	Inside Diameter		Outside Diameter		Thickness	
	Max	Min	Max	Min	Max	Min
1/4 0.250	0.267	0.256	0.536	0.500	0.045	0.035
5/16 0.3125	0.332	0.320	0.607	0.590	0.050	0.040
3/8 0.375	0.398	0.384	0.748	0.700	0.050	0.042
7/16 0.4375	0.464	0.448	0.858	0.800	0.067	0.050
1/2 0.500	0.530	0.512	0.924	0.880	0.067	0.055
9/16 0.5625	0.596	0.576	1.034	0.990	0.067	0.055
5/8 0.625	0.663	0.640	1.135	1.100	0.067	0.059
3/4 0.750	0.795	0.768	1.265	1.240	0.084	0.070
7/8 0.875	0.927	0.894	1.447	1.400	0.084	0.075

NOTES:

- (1) For additional requirements, refer to Introductory Notes, page L-7, and to General Data for Tooth Lock Washers, page L-14.
- (2) All dimensions are in inches.